

RAIL BONDING

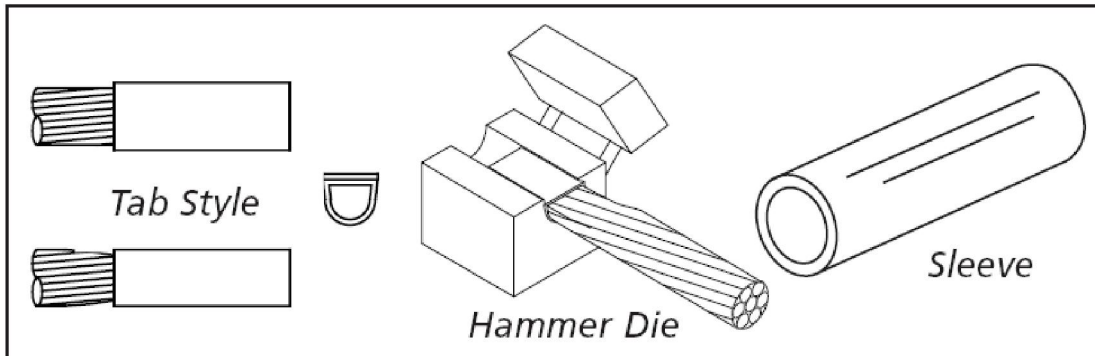

FIELD MADE BONDS

Tab-Style Terminals



Cable Size	Terminal Length	Sleeve Part Number	Pack Size	Hammer Die Part No
3/16 (5mm)	25mm	SBS12C	100	SBD50

SIGNAL CABLE

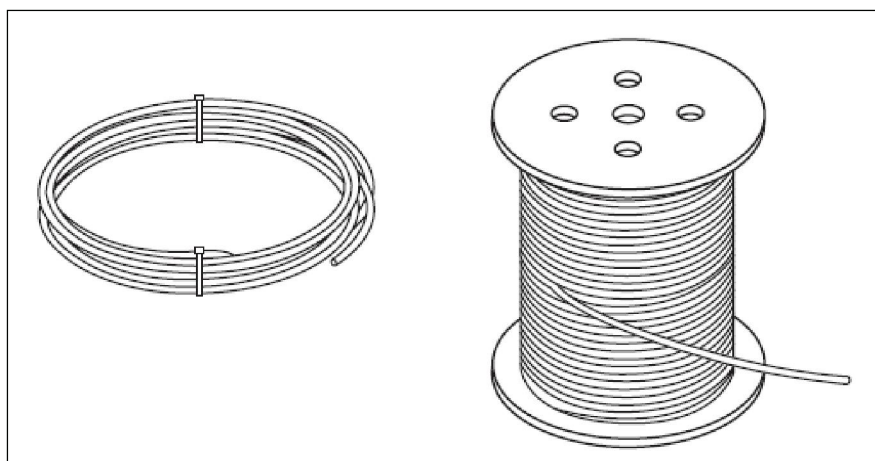

Part Number	Cable Size	Pack Size
SBS8CBARE	3/16 (5mm)	100' (30.48m)
SBS17CBARE	5/16 (8mm)	100' (30.48m)

RAIL BONDING

ERICO®

CADWELD
Bonding Kits

Head Bond Kits

Order in boxes of 100 x bonds - Includes one pair of new moulds, flint gun & welding material.



SB20175 Head Bond Kit 5/16 (8 x 180mm)

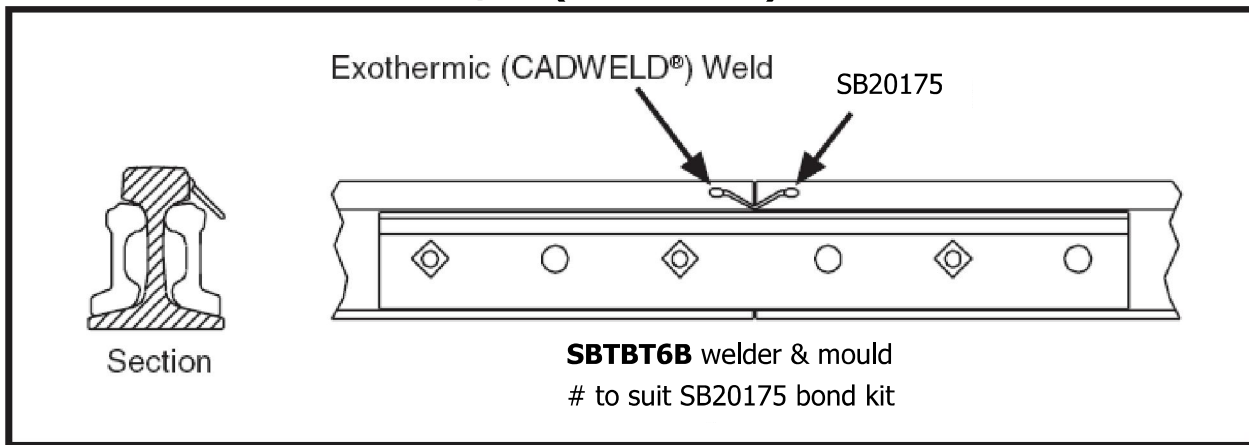

SBS24882 Signal Bond Kit 3/16 (5 x 165mm)

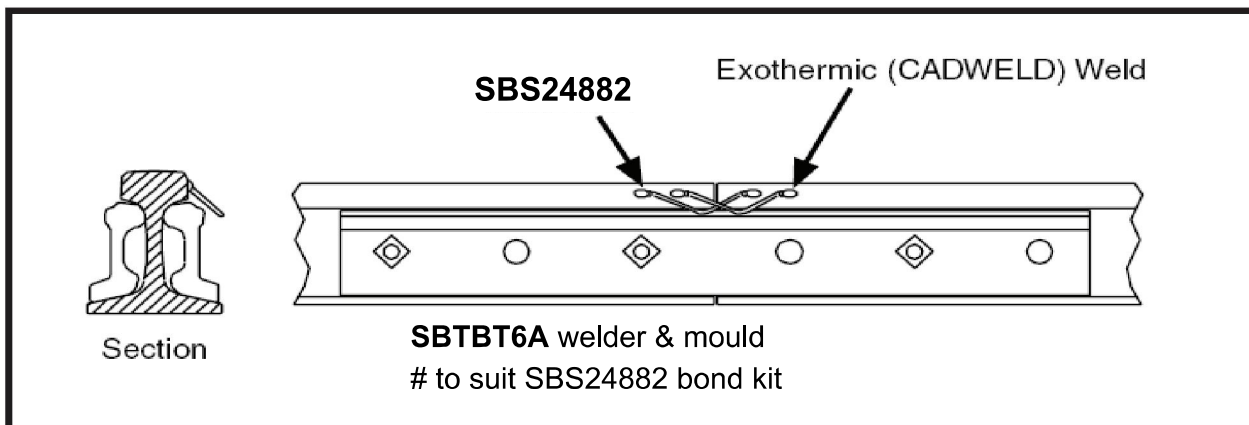

SBTBT6B welder & mould

SBTBT6A welder & mould

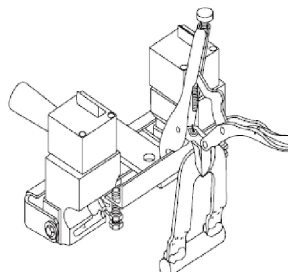

RAIL BONDING



CADWELD rail joint bonds provide:

- Maximum broken rail protection
- Unchanging electrical resistance
- Maximum corrosion resistance
- Easy installation, minimum installer skill required
- Simple & light portable installation equipment

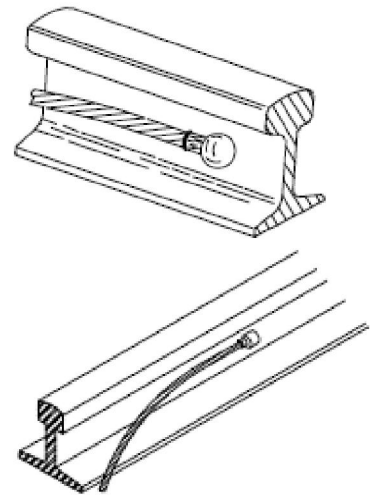

WELDERS & MOULDS

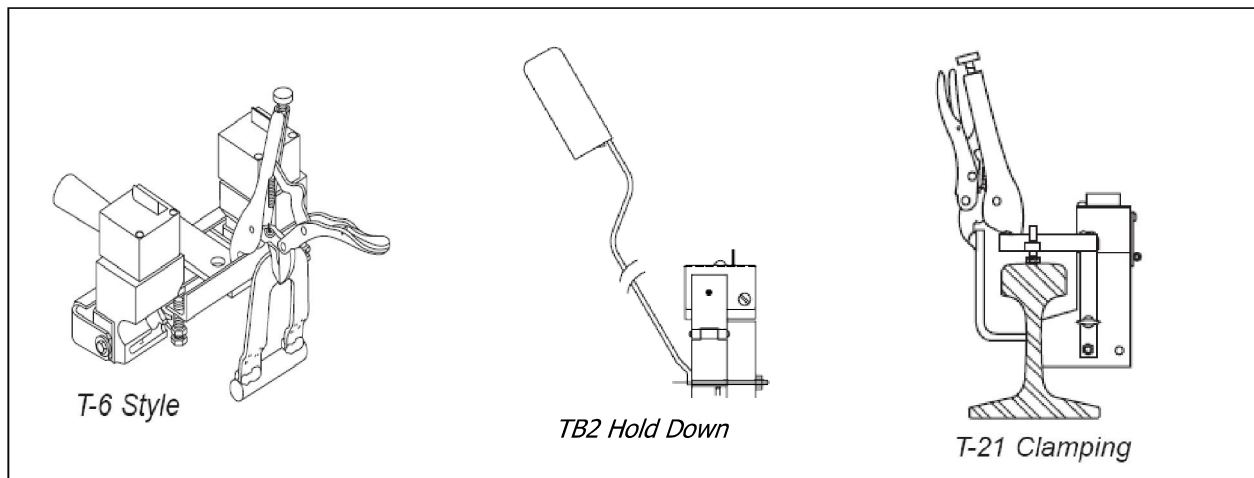

CADWELD rod to cable

13mm Rod to 3 X 16mm² Cable



Mould	Handle	Weld Metal	Flint Gun	Mould Sealer
NCRP013W3	L160S	F20-90	T320	T403